

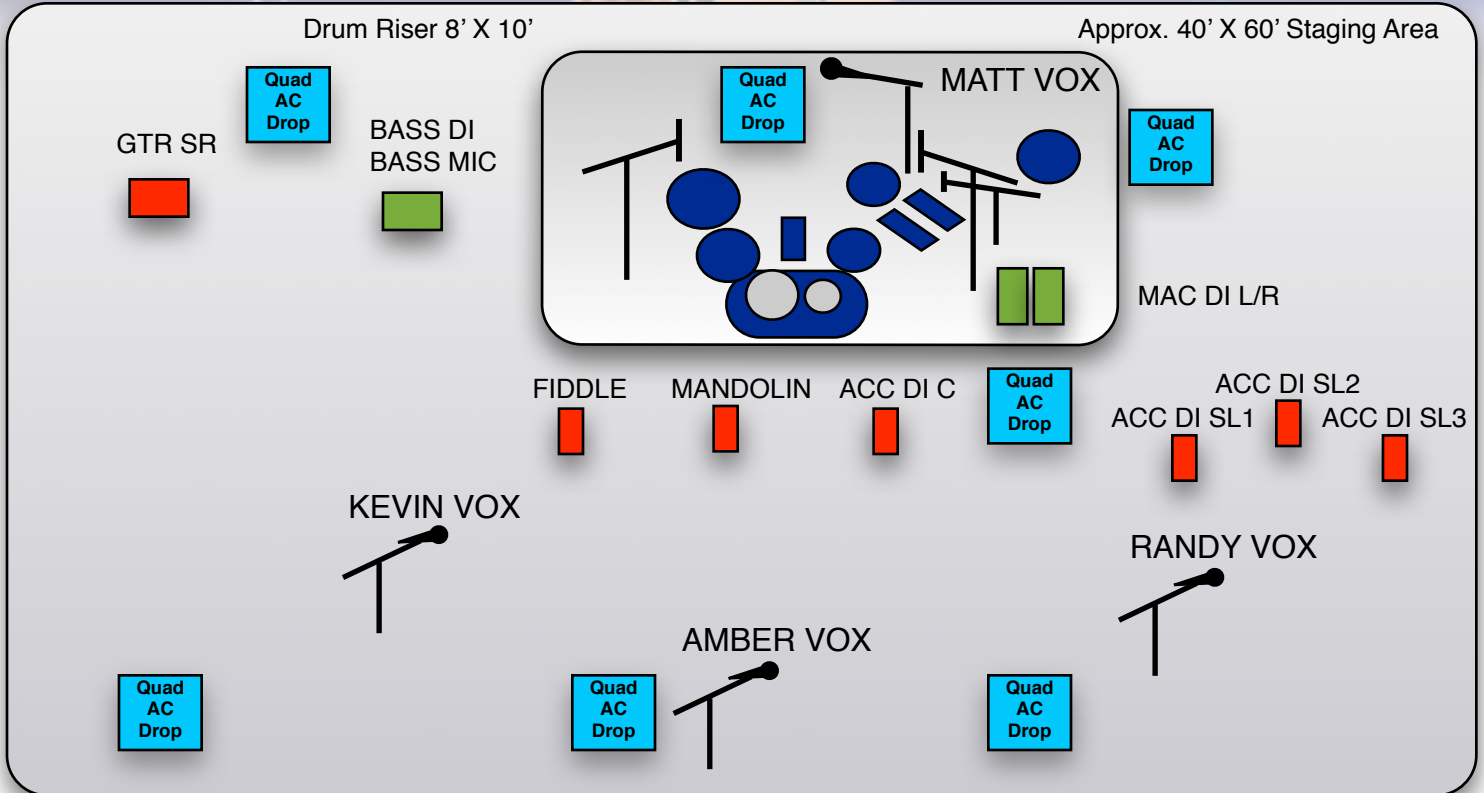

AMBER LEIGH

STAGE PLOT - REV. 090111



INPUTS (ALL SENNHEISER MICS UNLESS OTHERWISE NOTED)

- | | | | |
|----|---|----|--|
| 1 | SUB-KICK (ARTIST PROVIDES) COMP | 25 | FIDDLE C (WIRELESS PROVIDED) COMP/LIM |
| 2 | KICK 1 (E602/E902) COMP, GATE, SHORT BOOM | 26 | MANDOLIN (RADIAL J48/COUNTRYMAN 85) COMP |
| 3 | KICK 2 (E901) COMP, GATE | | |
| 4 | SNARE 1 TOP (E604/E904) COMP, GATE | 27 | DRUM TB VOX (E945) GATE, TALL BOOM |
| 5 | SNARE 1 BOTTOM (E905) GATE, SHORT BOOM | 28 | SR GTR TB VOX (E945) GATE, TALL BOOM |
| 6 | SNARE 2 TOP (E604/904) COMP, GATE | 29 | SR BASS VOX (E965) GATE, COMP, TALL BOOM |
| 7 | SNARE 2 BOTTOM (E905) GATE, SHORT BOOM | 30 | SL ACC VOX (E965) GATE, COMP, TALL BOOM |
| 8 | HI HAT (E614)*, BOOM | 31 | AMBER VOX (WIRELESS 3K/5K, KK105 CAP/E965 CAP;
WIRED NEUMANN KMS105), TALL BOOM |
| 9 | RACK 1 (E604/904) GATE | 32 | B/U AMBER VOX - MATCH CH. 30 (OPT.) |
| 10 | RACK 2 (E604/904) GATE | | |
| 11 | FLOOR 1 (E904/441/421) GATE | | |
| 12 | FLOOR 2 (E904/441/421) GATE | | |
| 13 | OH SL (MK4/E614)* | | |
| 14 | OH C (E614) | | |
| 15 | OH SR (MK4/E614)* | | |
| 16 | LAPTOP DI L (RADIAL JDI/COUNTRYMAN 85) | | |
| 17 | LAPTOP DI R (RADIAL JDI/COUNTRYMAN 85) | | |
| 18 | BASS DI (RADIAL JDI/COUNTRYMAN 85) COMP | | |
| 19 | BASS MIC (421/E602) | | |
| 20 | ELEC. GUITAR SR (E906) | | |
| 21 | ACC GTR SL1 (RADIAL J48/COUNTRYMAN 85) | | |
| 22 | ACC GTR SL2 (RADIAL J48/COUNTRYMAN 85) | | |
| 23 | ACC GTR SL3 (RADIAL J48/COUNTRYMAN 85) | | |
| 24 | ACC GTR C (RADIAL J48/COUNTRYMAN 85) COMP | | |

FOH CONTACT:

HOLLAND RYAN

(561) 504-5138 • hcryan@gmail.com

BAND CONTACT:

RANDY JAMES

(561) 289-6622 • randyj200@aol.com

WWW.AMBERLEIGH.COM

Copyright ©2011 THE ECI GROUP.. All rights reserved.